

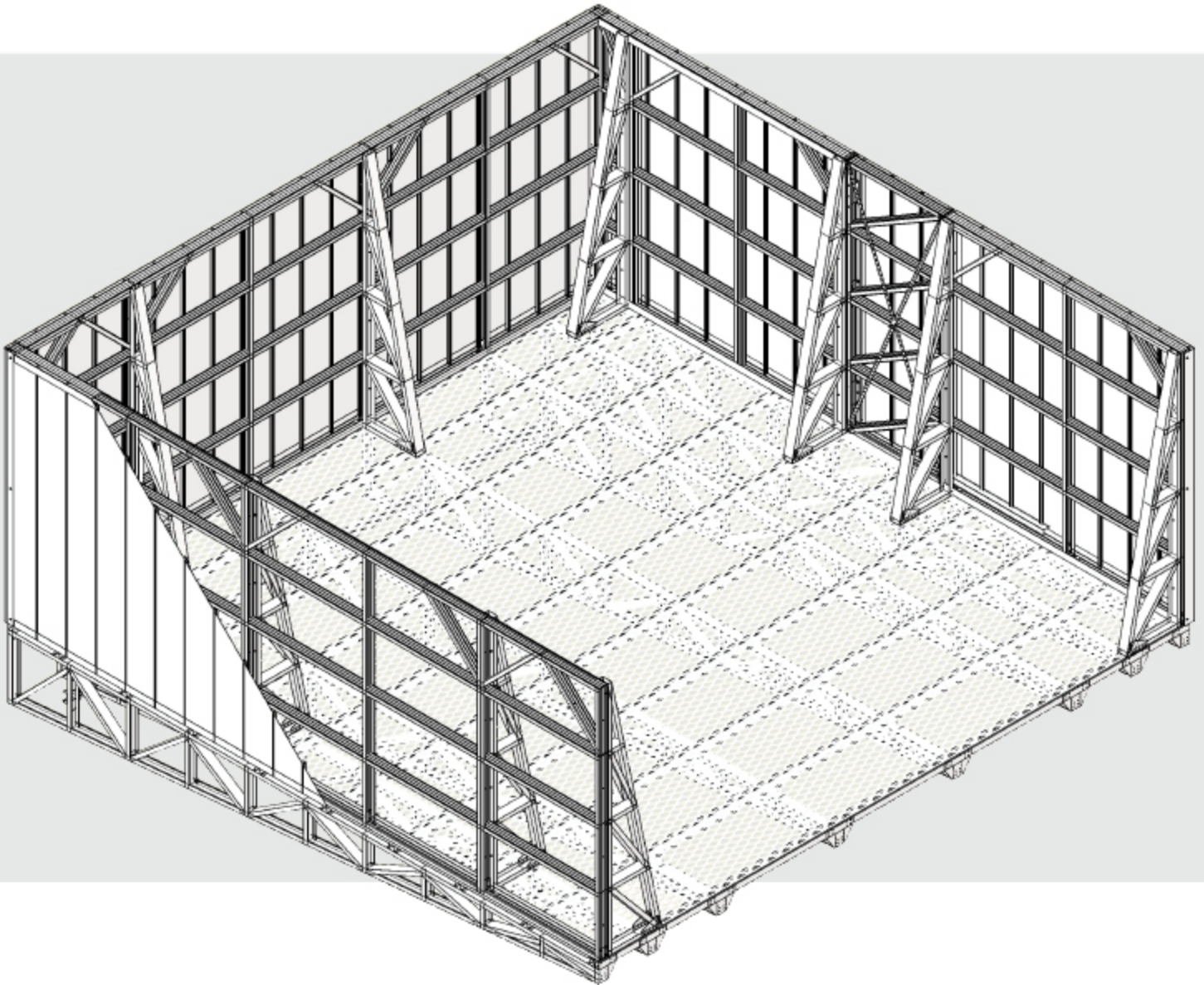

Screens

Assembly Instruction Manual



Con-form[®]
GROUP
Making it *Easy*

 1300 882 490

 info@con-formgroup.com.au

Screens & Acoustic Solutions Assembly Manual

Document Version: 24-09-02-v1.8

Contents

- > Screen Framing Assembly to Platform
- > Conceal Wall (also applicable for Conceal AeroWall & Acoustic+ Screen)
- > Louvre Wall (Airflow)
- > Door Frame Assembly

Tools required

- > Cordless Drill
- > Hammer
- > Tape Measure
- > 13mm Socket
- > 5/16th Extension Driver Bit
- > Level

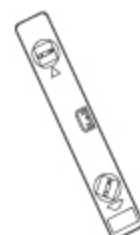

Assembly Parts

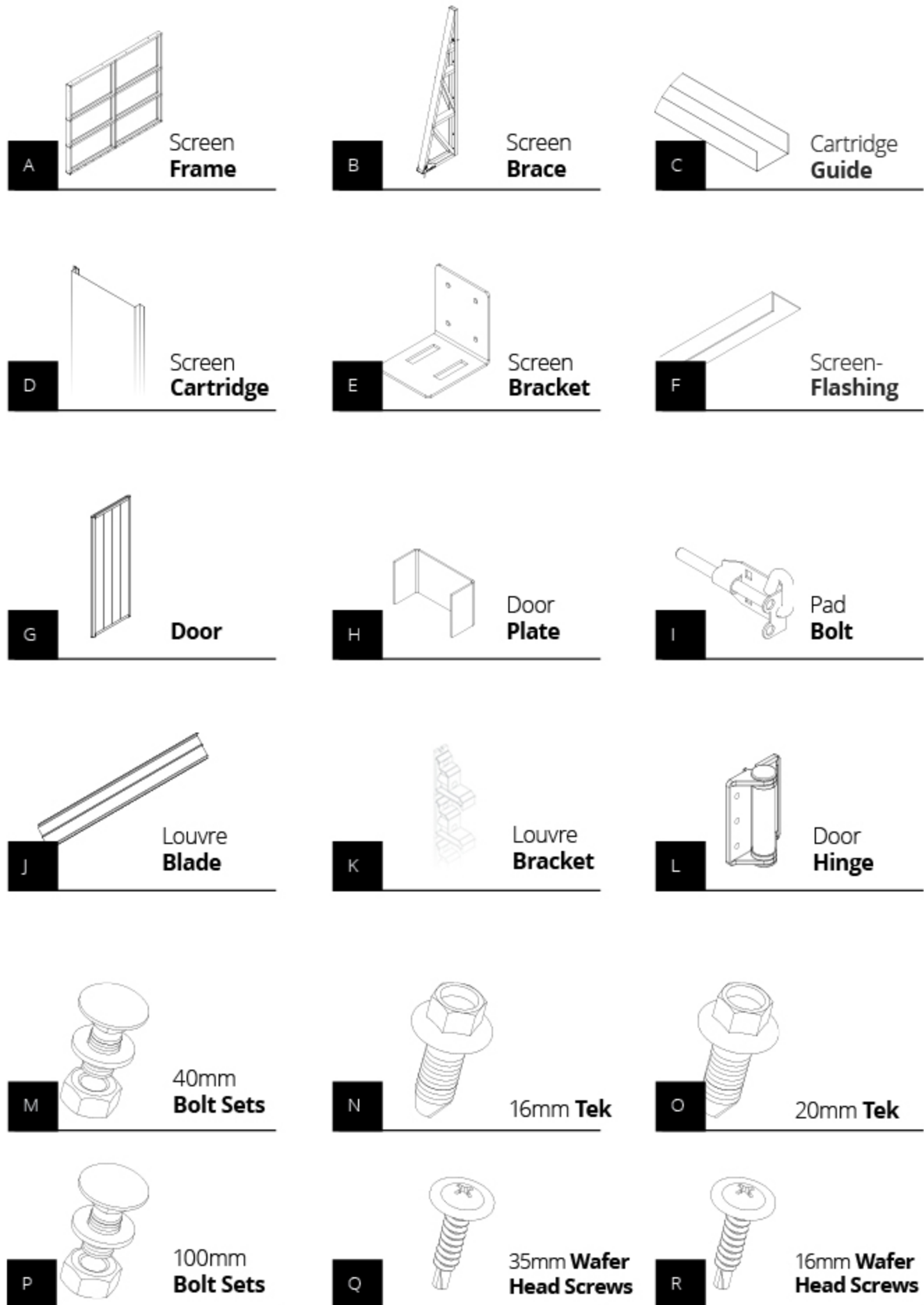

Screen Framing Assembly

Screen Framing Assembly

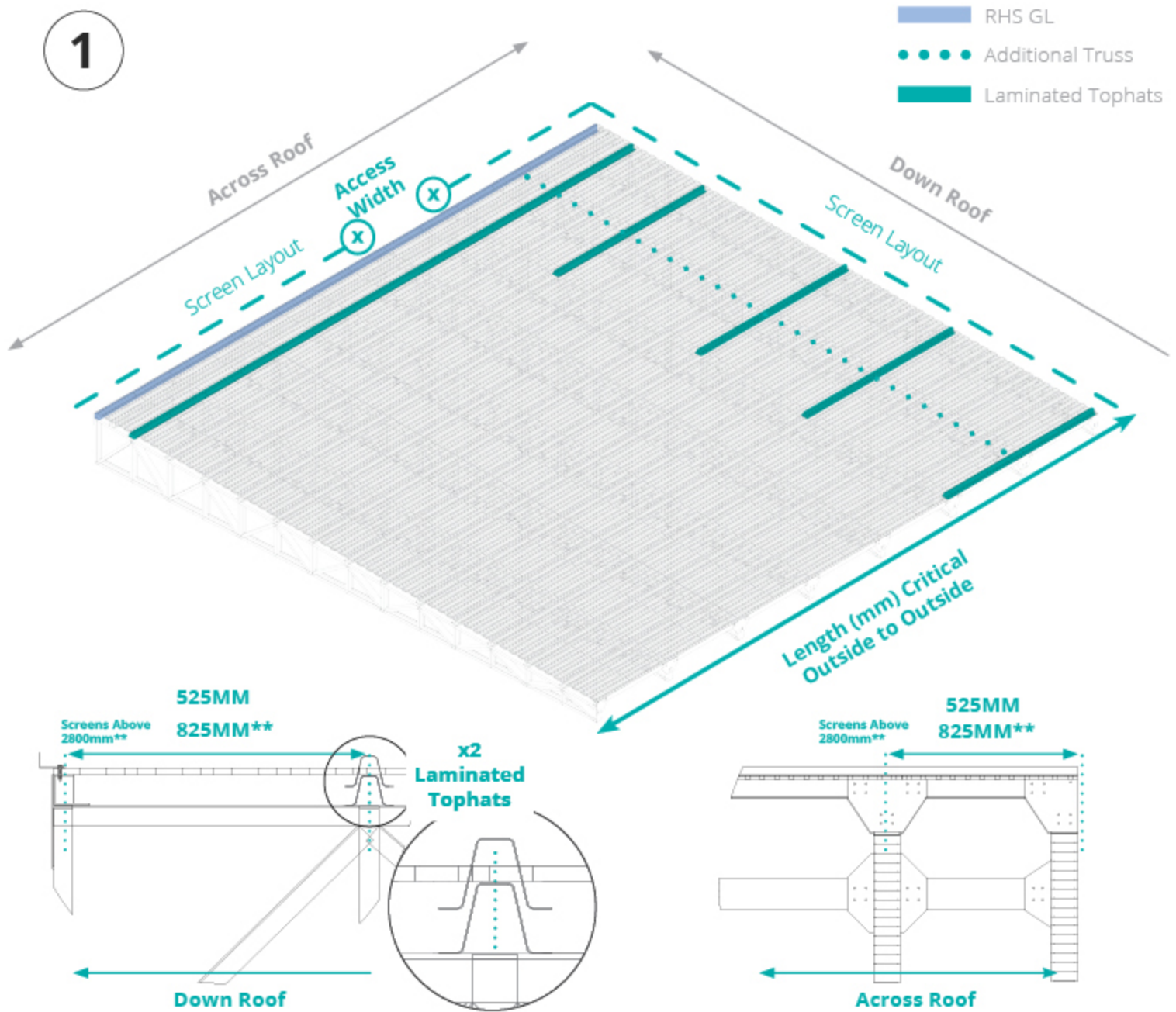

1. Establish from your structural drawing which sides screens will be fitted to. If there are any access gaps, mark the location of the screen ends and access gaps on the platform frame. If a Door is present leave opening clear. Ensure there is **x2 Laminated Tophats** 525mm back from the front face of platform. At the sides make sure there is a additional truss at 525mm from the outer edge of the platform to the centre of the truss.

Screen Framing Assembly

2

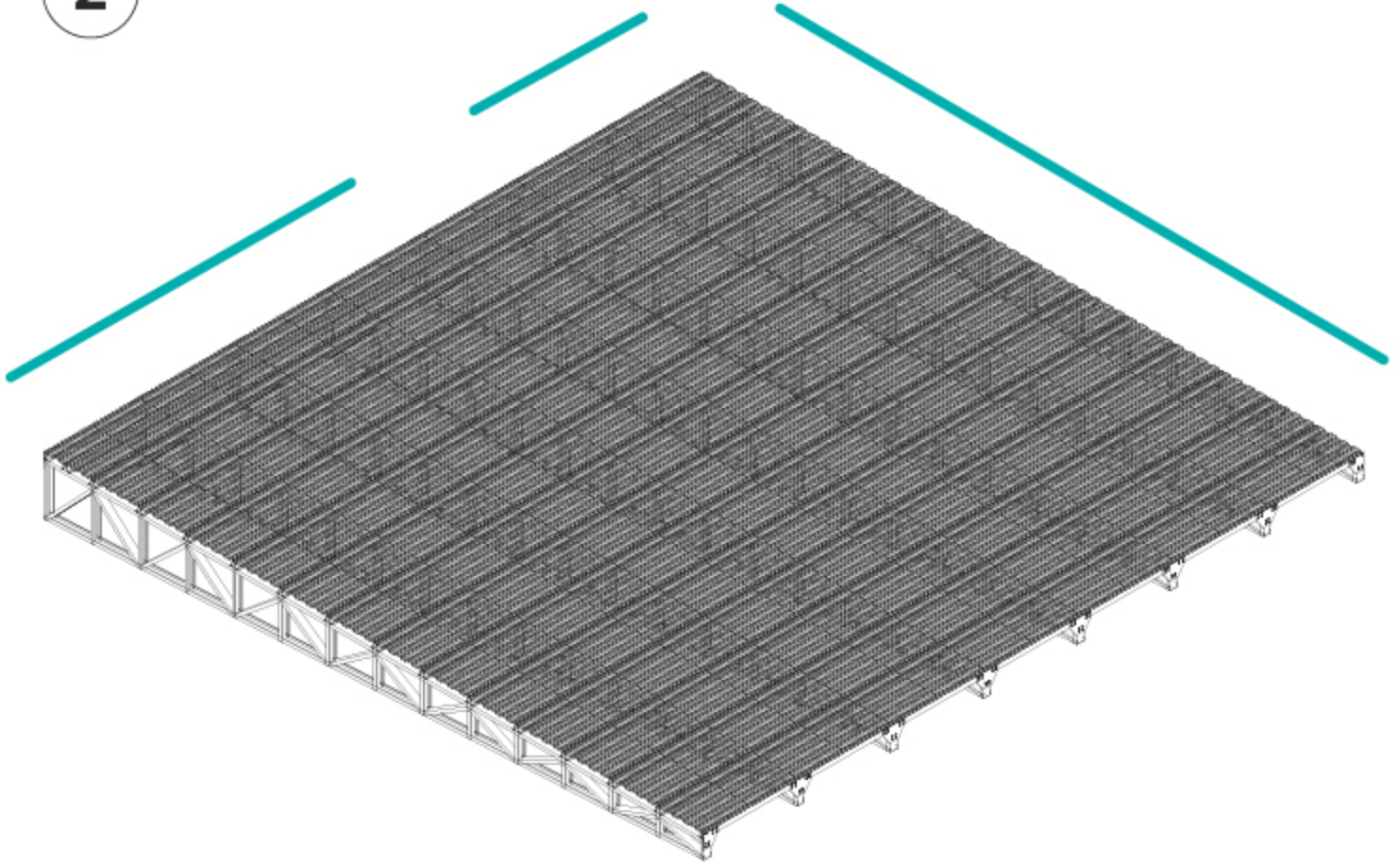

2. Lay the **Screen Frames (A)** around the outer perimeter of the platform in their correct positions. For each side, begin with a full 2400mm Screen Frame from the inside right corner and work to the left, ending with the odd sized frame at the inside left end.

Screen Framing Assembly

3

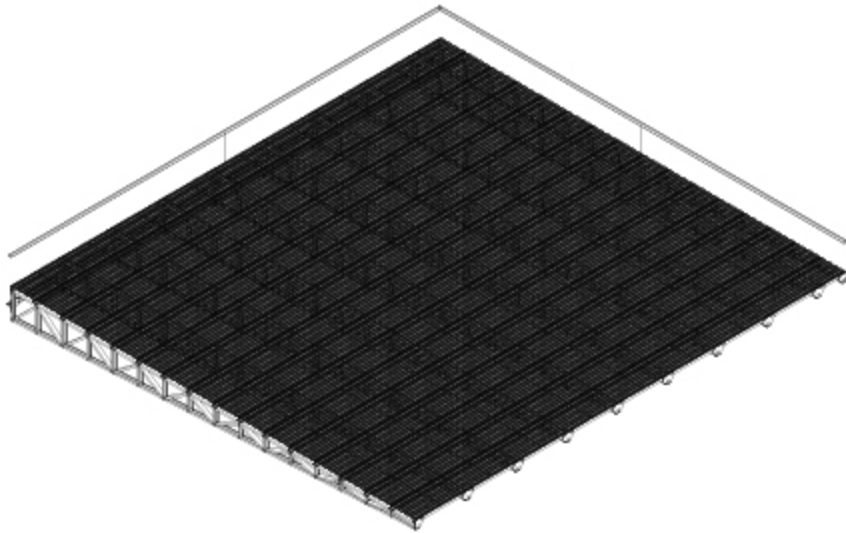

Parts required

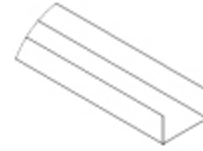

Cartridge
Guide



35mm **Wafer**
Head Screws

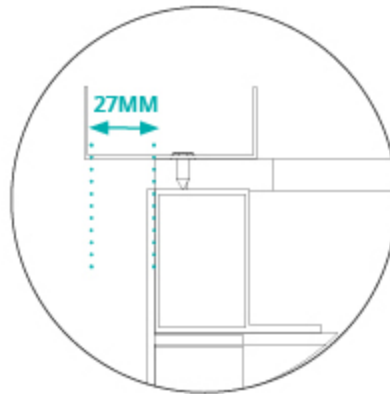
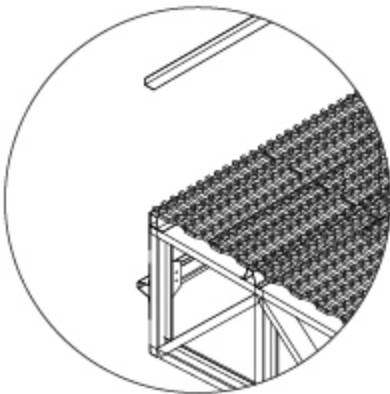

3. Fix the **Cartridge Guide (C)** to the platform using **35mm waferhead screws (Q)** at 600mm centres. Leave 27mm from the face of the platform to the inner face of the guide for the cartridges. Insert a cartridge at each end of the guide to ensure the gap is correct.

Screen Framing Assembly - Across Roof

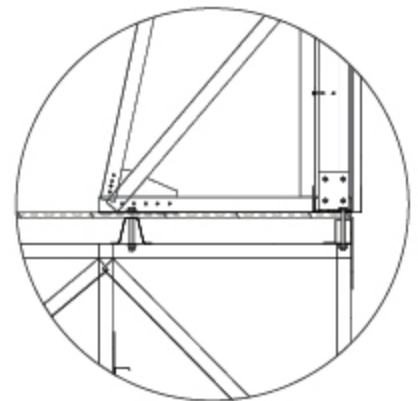
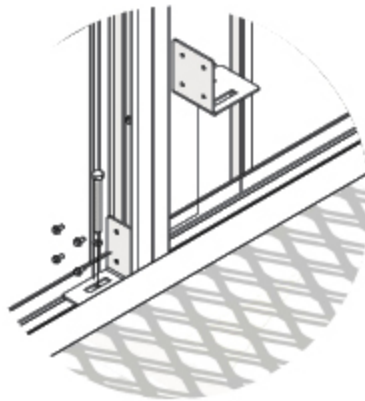
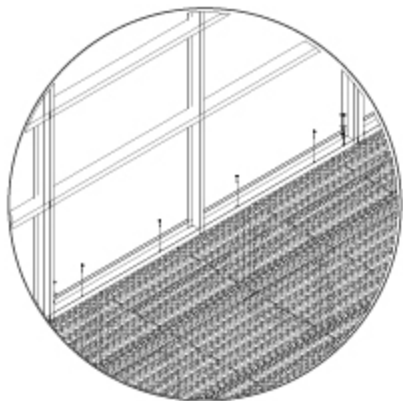
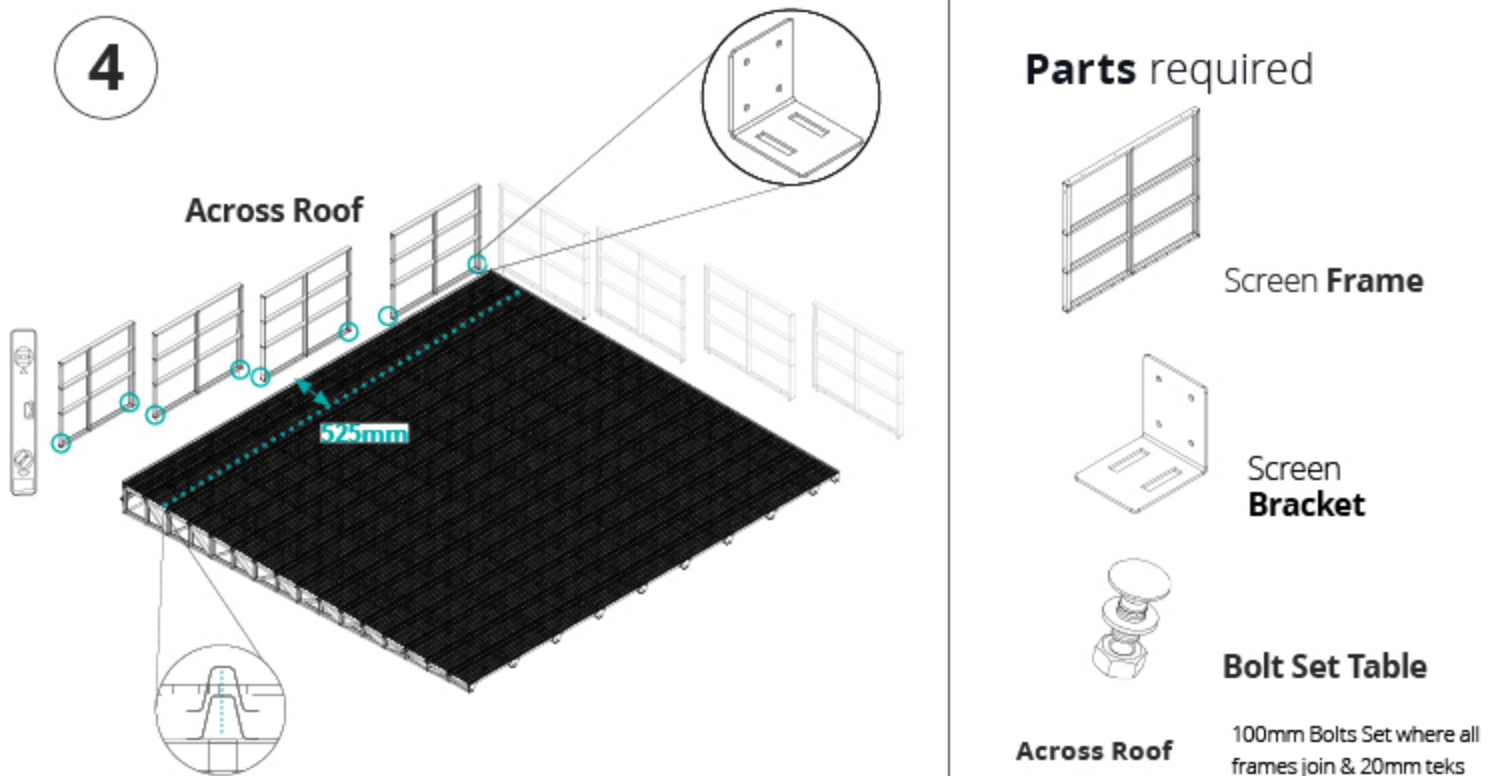

4. First, screw the frames to the perimeter of the platform at 600mm centres. Use 35mm needle point screws for the sides of the platform through the top hats, and use 20mm tek screws at the front and back of the platform through the RHS.

At the front & back of the platform, bolt all screen frames, at both corners of the screen frame, to the RHS of the platform using a Screen Bracket (E), 100mm M10 bolt with washers.

Screen Framing Assembly - Down Roof

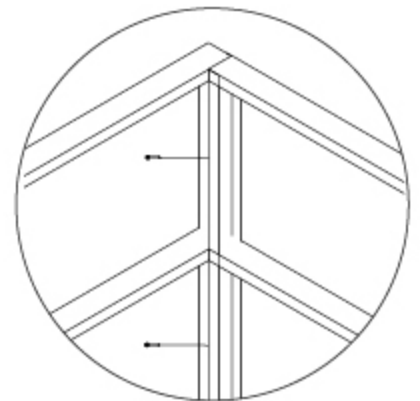
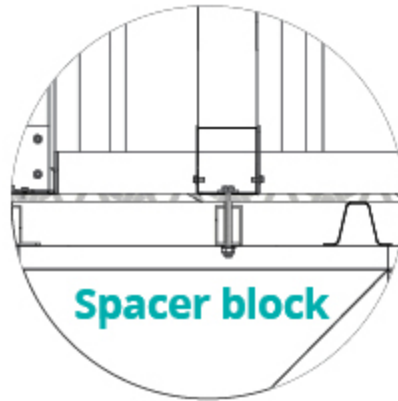
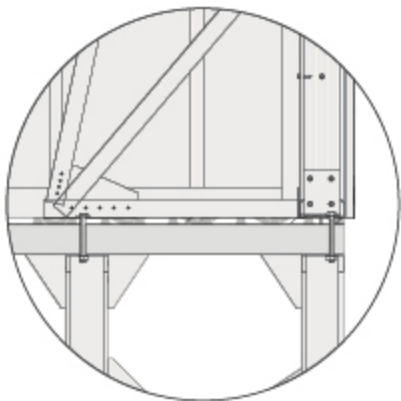
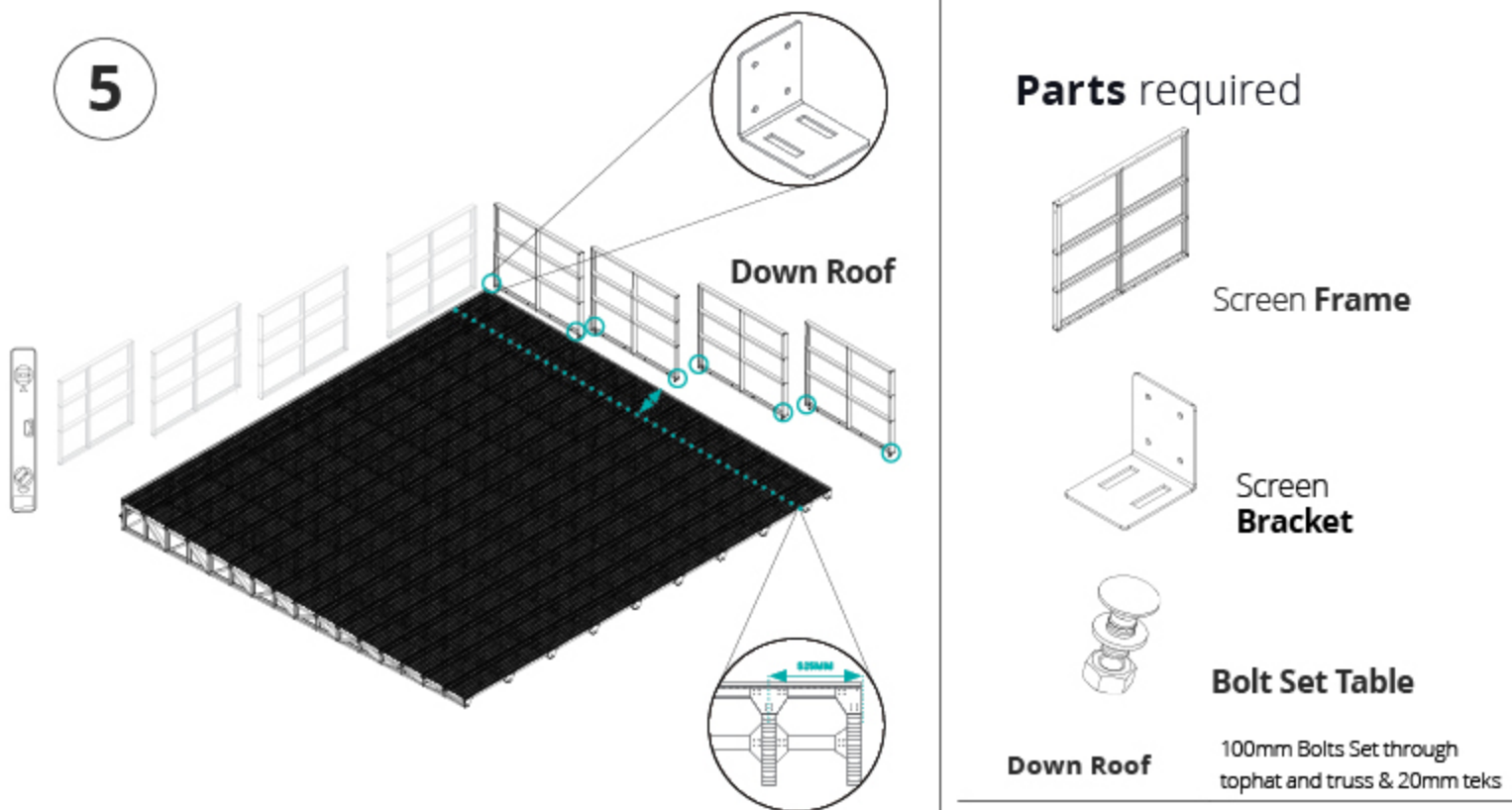

5. At the left & right sides of the platform, bolt all screen frames, at both corners of the screen frame, through the top hat and top chord of the truss using a Screen Bracket and 100mm M8 bolt with washers. **Note:** An RHS spacer block is required if the bolt does not align with the top hat.

Finally, stitch all frames together vertically with 20mm tek screws (O)

Screen Framing Assembly

6

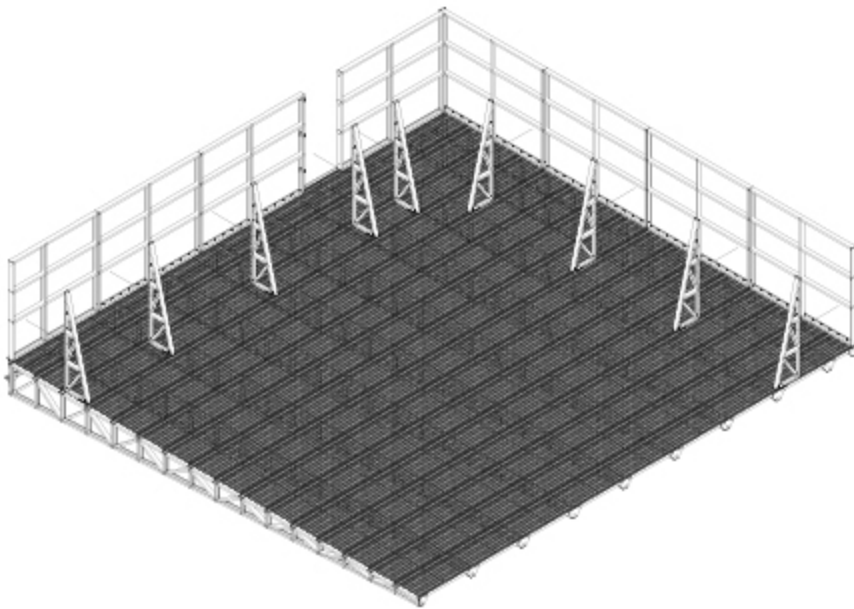

Parts required

Screen **Brace**Top Hat **Spacer****Bolt Set Table**

Front & Back	100mm Bolt at base 40mm Bolt at top
Sides	100mm Bolt at base + Top Hat Spacer 40mm Bolt at top

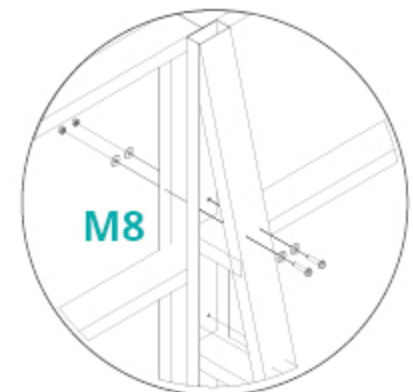
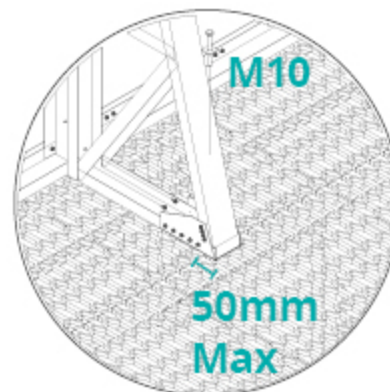
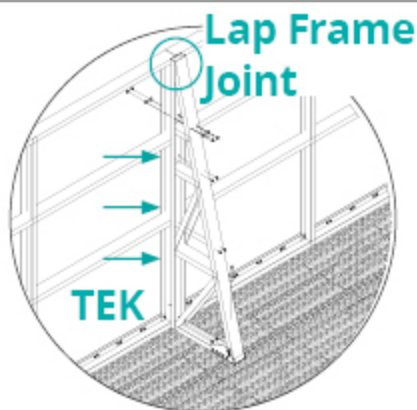

6. Fix the **Screen Braces (B)** to the platform and frames. At the base, drill an 11mm clearance hole through the RHS, corresponding with the rear hole in the screen brace, and fasten with one **M10 100mm bolt and washer (P)**. Ensure **Strengthening Bracket** is installed. Bolt must be **within 50mm** of end of angled member of **Screen Brace**. At the top of the brace, drill a 9mm clearance hole at each side of the screen frames and brace and fix with two **M8 40mm bolts and washers (M)**. Then fix the brace to the screen frames using **20mm tek screws (O)** at 600mm vertical centres.

Conceal Wall, Conceal AeroWall & Acoustic+ Screens

Conceal & Acoustic+ Screens

6

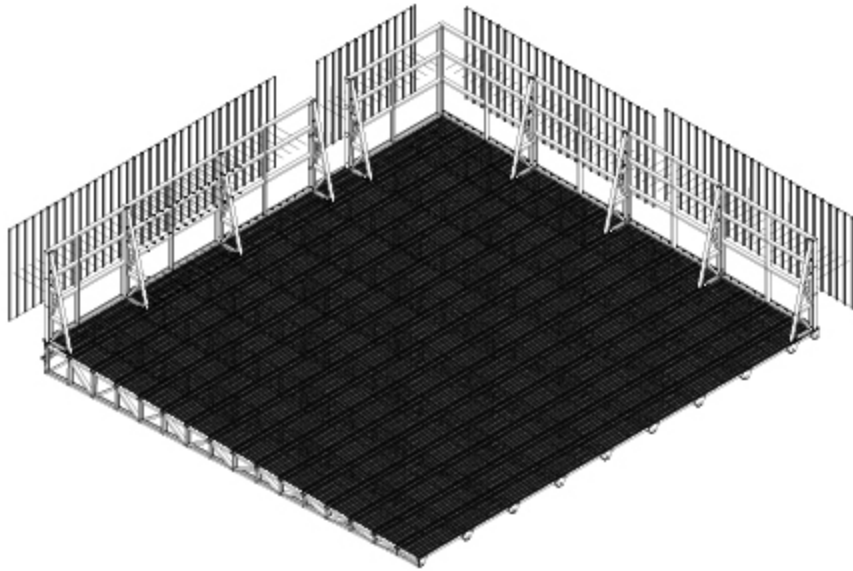

Parts required



Screen **Cartridge**



16mm **Wafer Head Screws**

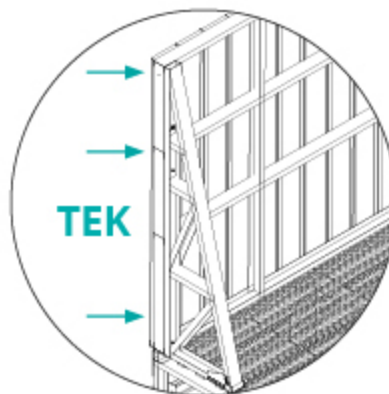
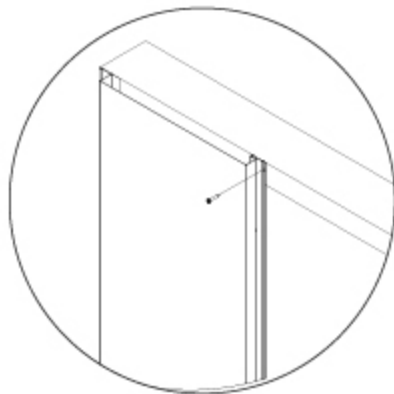

6. Insert the **Cartridges (D)** into the **Cartridge Guide (C)**, starting from left to right, making sure that the first cartridge is flush with the screen frame and the female side is on the right. Fix the screen cartridges to all nogginns of the screen frame using **16mm wafer head screws, on the right hand side of the cartridge only (R)**. Ensure they are tight together and do not creep. There will be a 10mm shadow line. Note: If there is a door, it may be advisable to begin the installation from the door and work outwards in both directions.

Conceal & Acoustic+ Screens

7

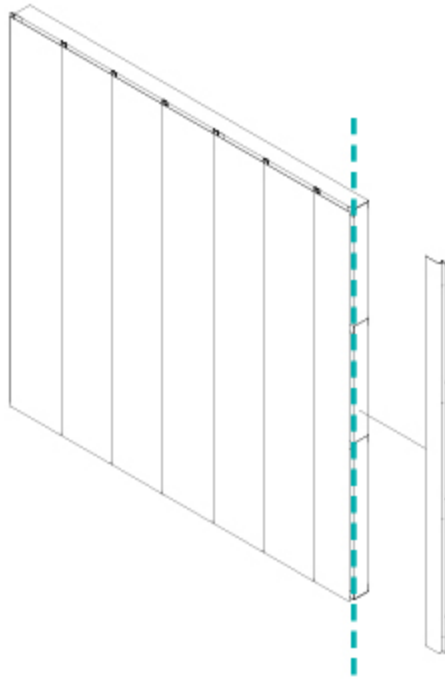

Parts required



Screen **Cartridge**



16mm **Tek Screws**

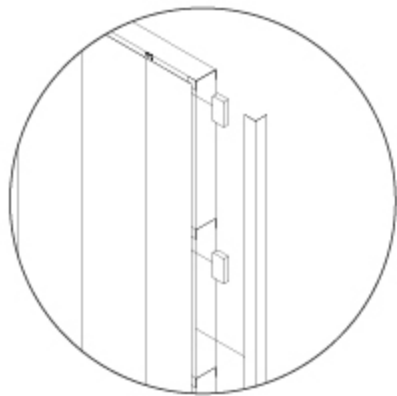

7. Trim the last **Screen Cartridge (D)** to the edge of the screen frame, and insert 25mm **Acoustic packer**. Finish the ends of the screen with **Corner Flashings (F)**.

Louvre Wall

Louvre Wall

8

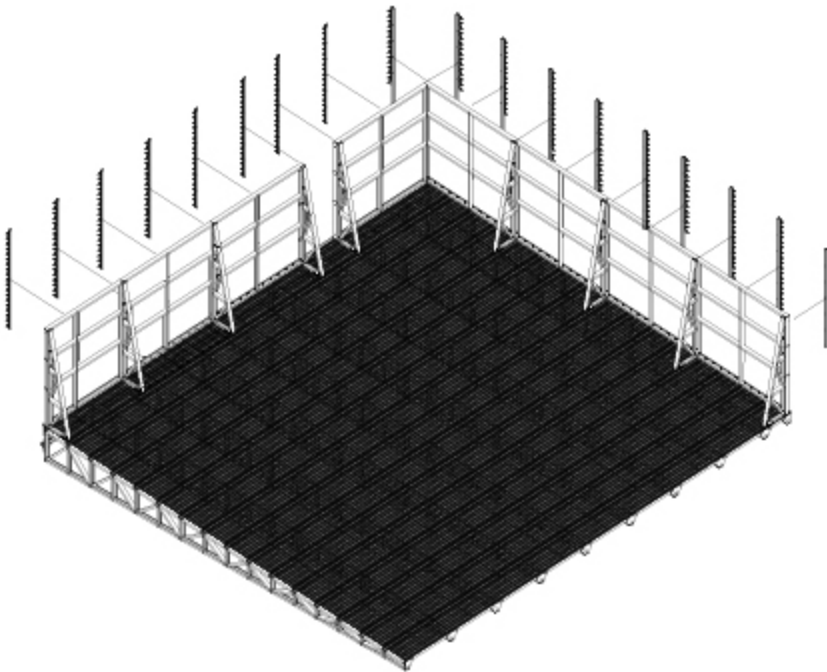

Parts required



Louvre
Spacer Bracket



20mm Tek Screws

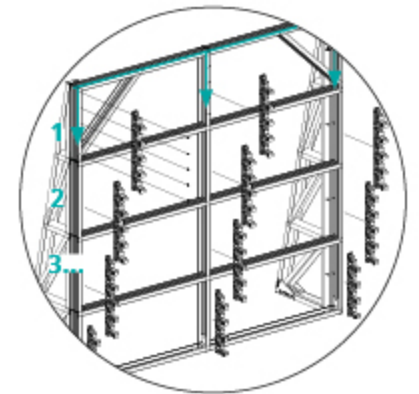
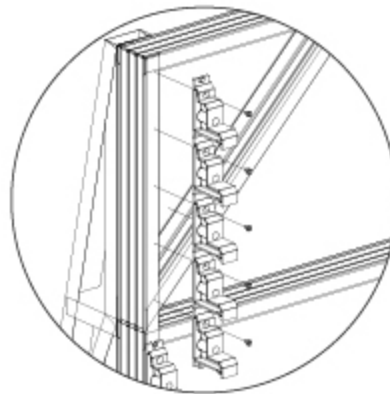
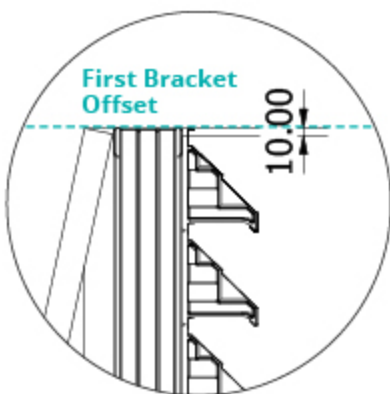

8. Starting from the **top** of the frame and **working downwards**, ensure there is a **10mm Offset** from top of frame to top edge of bracket. Fix the **Louvre Spacer Bracket (K)** to the Screen Frame at no greater than 1200mm centres using five x **20mm Tek Screws (O)**.

Louvre Wall

9

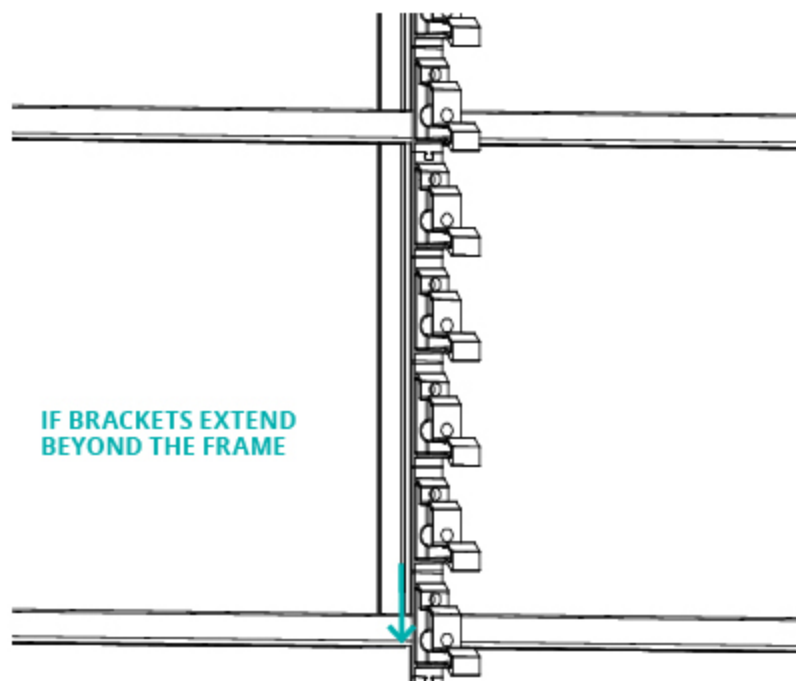

Parts required



Louvre
Spacer Bracket

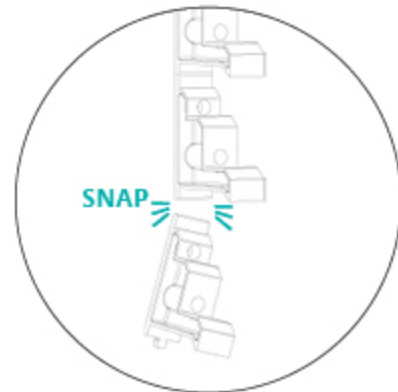
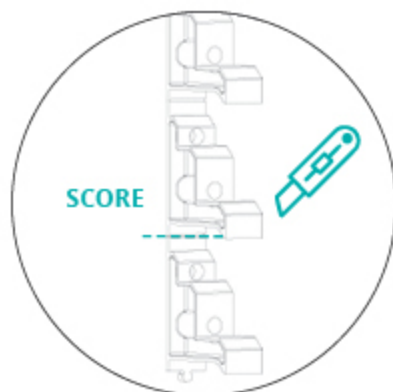
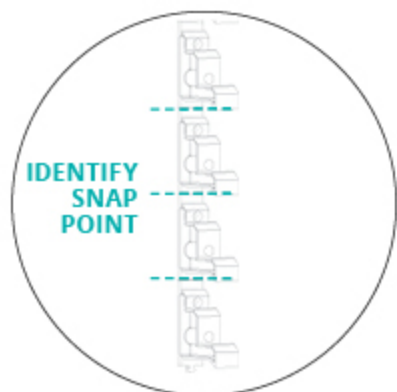

9. If the **Louvre Spacer Bracket (K)** is too long for the frame, score the bracket at the appropriate recess pocket then snap excess portion off.

Louvre Wall

10

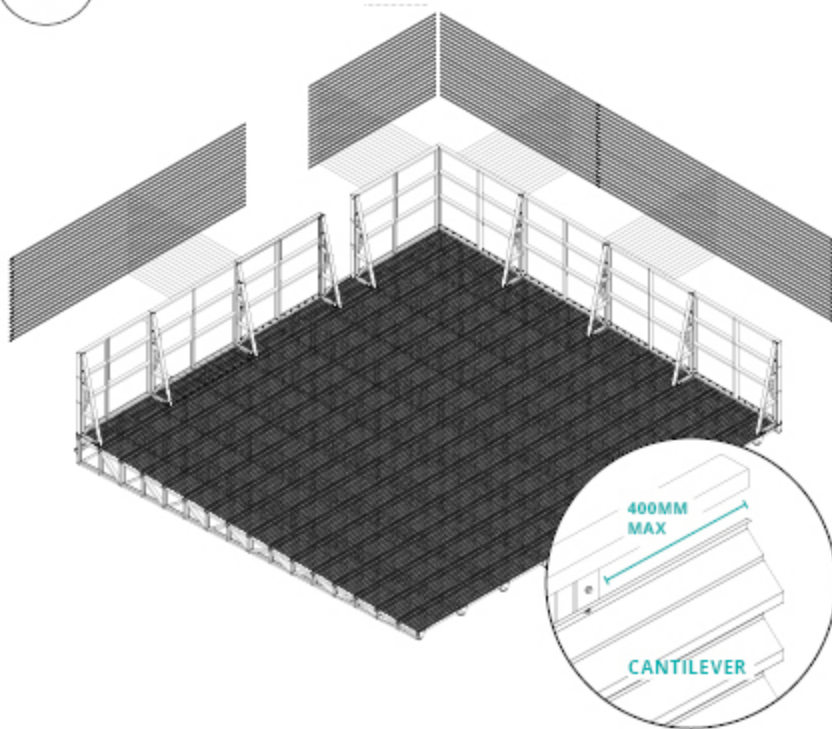

Parts required

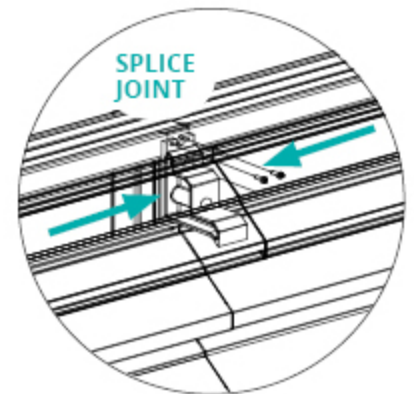
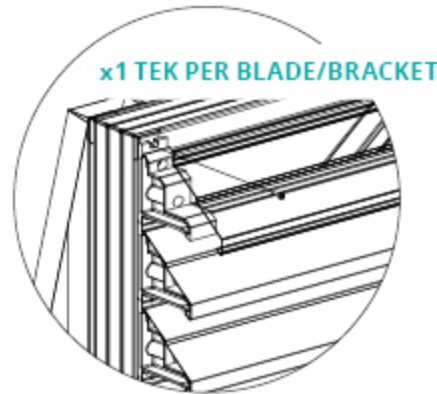
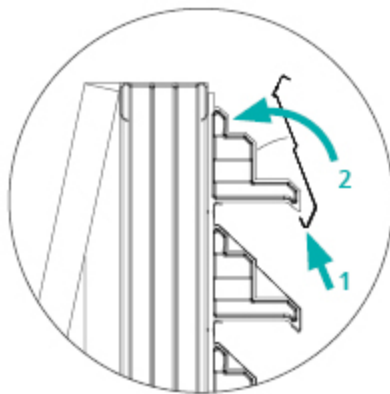
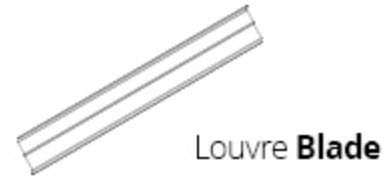

9. Fix the **Louvre Blades (J)** to the Louvre Bracket using **Wafer Head Screws (R)** through into the Screen Frame. Fix blade at every **Bracket**. Note: **maximum cantilever** of screen from the bracket shall be no greater than **400mm**.

Door Frame Assembly

Door Frame Assembly - Classic/Acoustic+

10

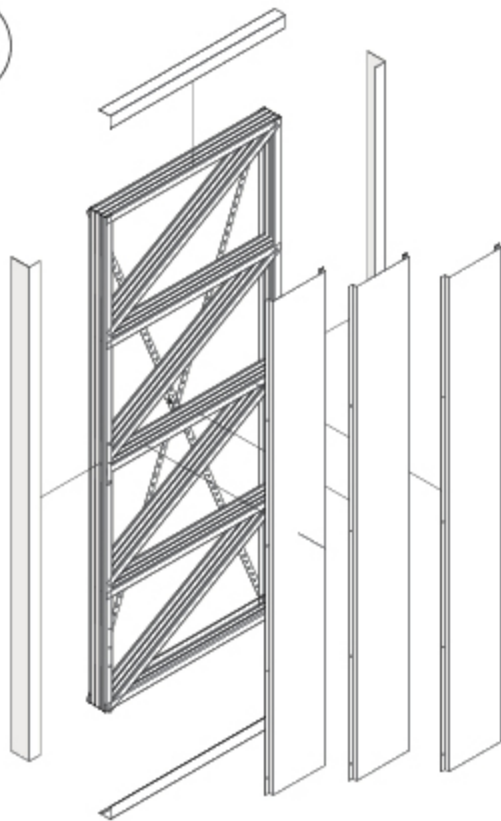

Parts required



Screen **Cartridge**



Door **Frame**



Door **Plate**



16mm **Wafer
Head Screws**



Door **Flashings**



Frame **Strapping**

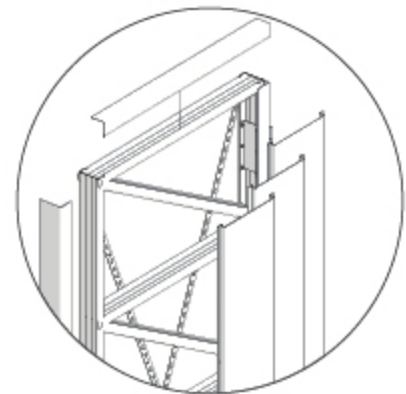
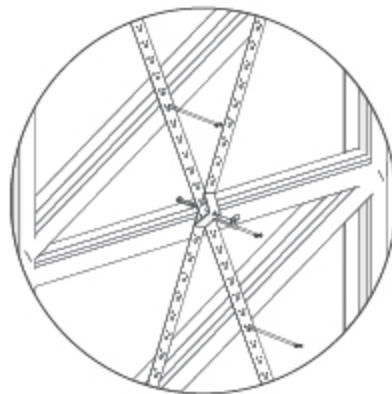
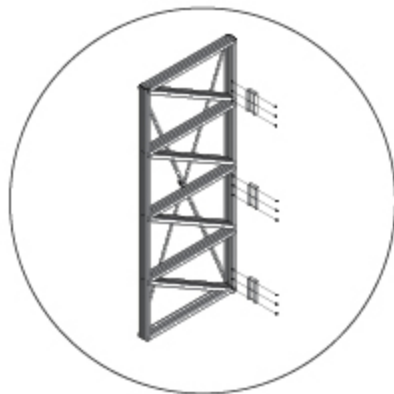

10. Insert the **Door Plates (H)** into **Door Frame** located where to reinforce the door hinges. Install **Frame Strapping** and fix with **20mm Tek's (O)** at every intersecting frame member. Tighten **Frame Strapping Bolt**. Install **Cartridge Panels (D)** as per step 6. Install **Corner and Top and Bottom Flashings (F)** supplied.

Door Frame Assembly - Louvre Screens

11

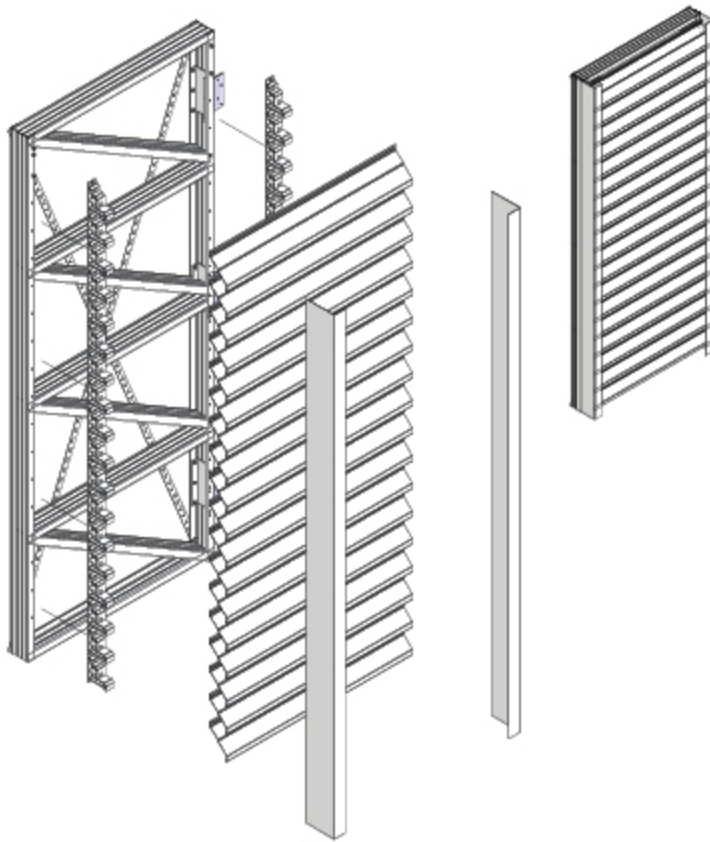

Parts required

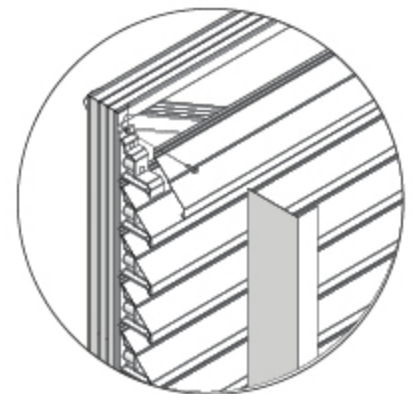
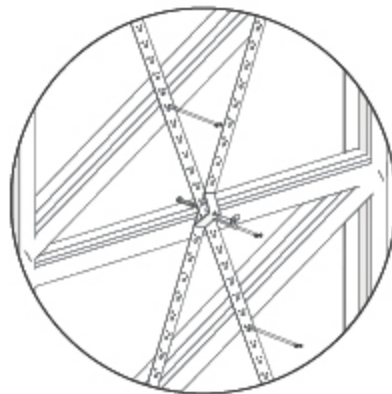
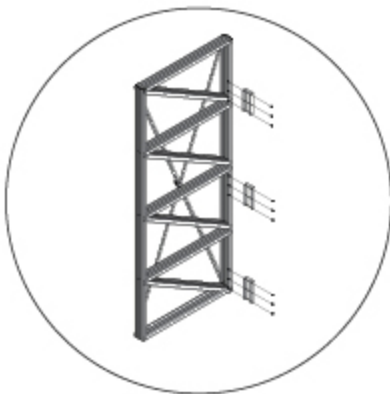
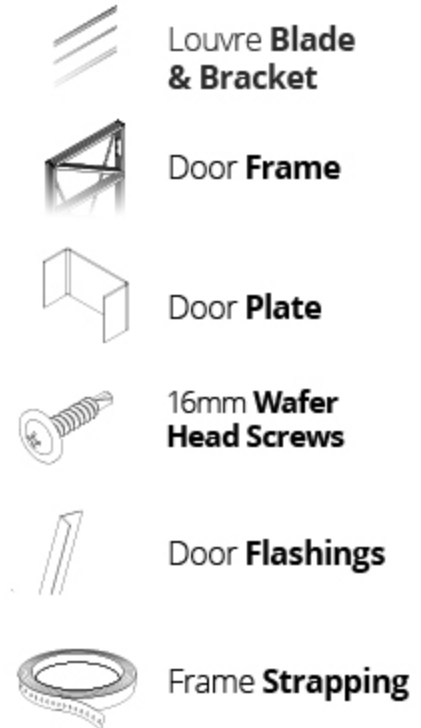

11. Insert the **Door Plates (H)** into **Door Frame** located where to reinforce the door hinges. Install **Frame Strapping** and fix with **20mm Tek's (O)** at every intersecting frame member. Tighten **Frame Strapping Bolt**. Install **Louvre Brackets and Blades (J & K)** as per step 8. Install **Corner Flashings (F)** supplied.

Door Assembly

12

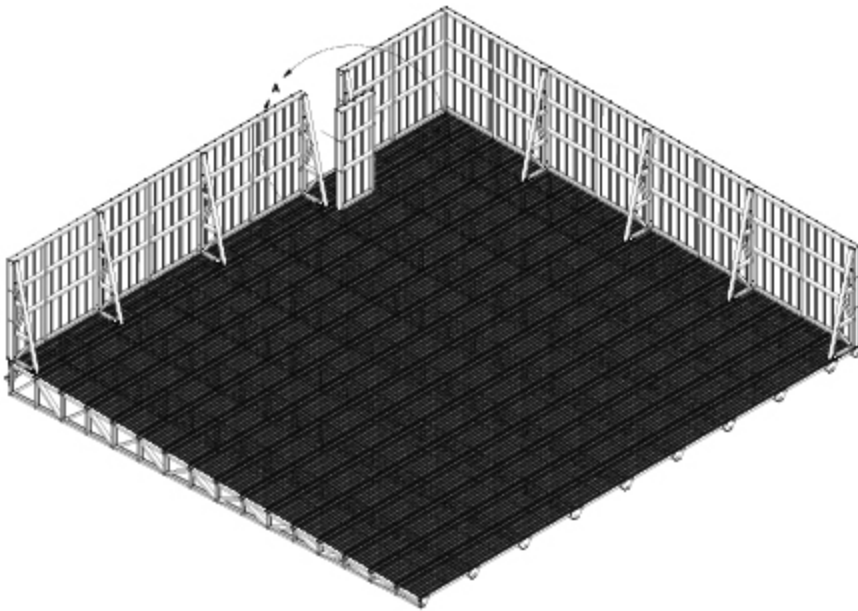

Parts required



Door



Door Plate



Door Hinge



Pad Bolt

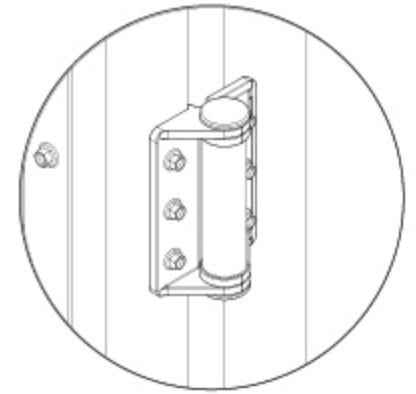
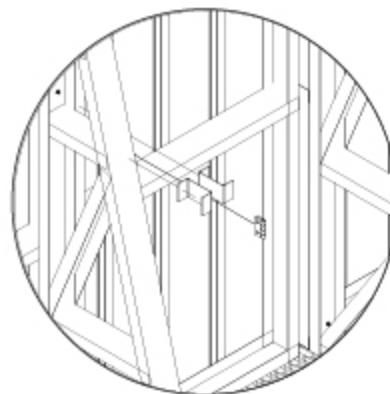
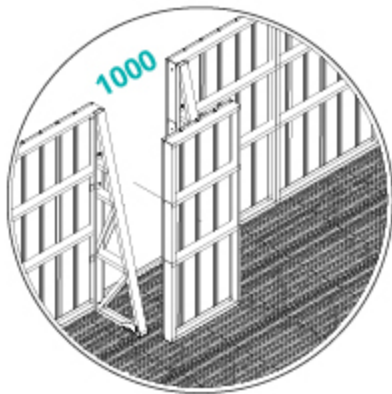

12. Fix a **Door Reinforcement Plate (H)** inside the vertical of the screen frame and door frame where the hinges are to be located using **20mm tek screws (O)**. Then fix the **Door Hinges (L)** to the Frame using **20mm tek screws (O)**. Fix the door to the hinges. Then fix the door **Pad Bolt (I)** to the outside of the door frame and screen frame.

Final Installation Steps

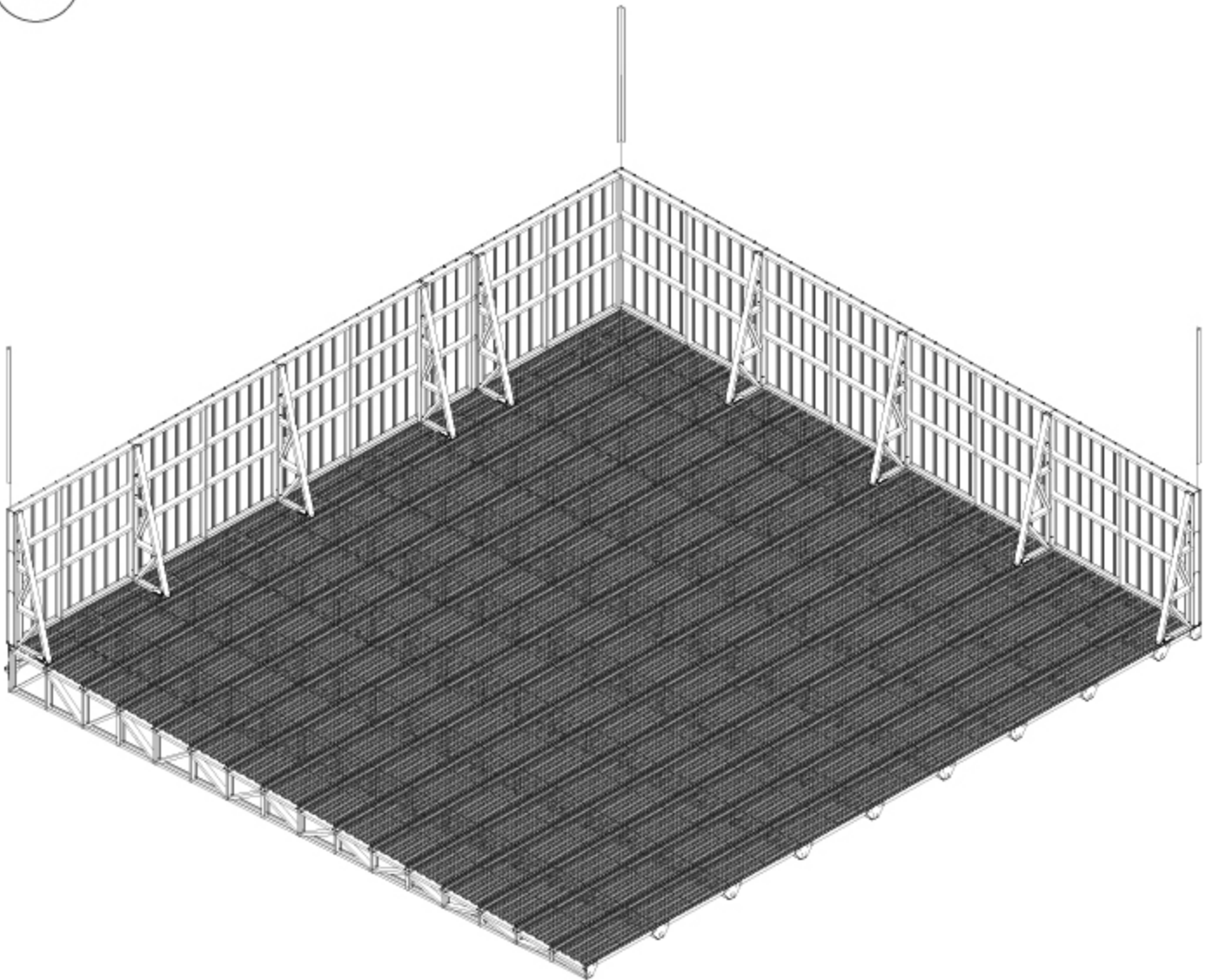
13

13. Add **Corner Flashings (F)** to the screen using **16mm tek screws (N)** at 1200 centres.

14

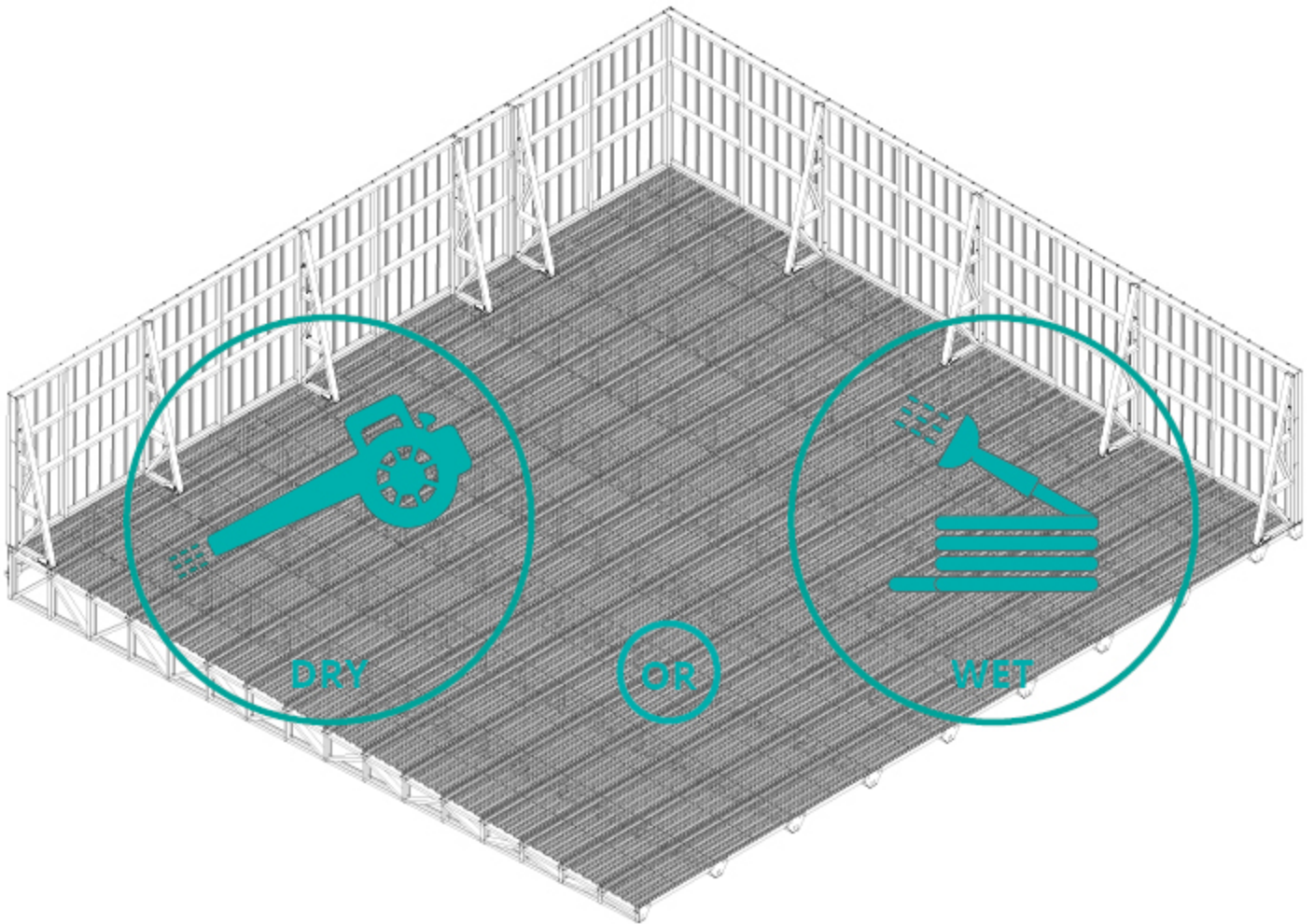

14. Vacuum swarf from the roof before cleaning with a petrol blower if the roof is dry and a hose if the roof is wet.

Con-form[®]
GROUP
Making it *Easy*



ABN 99 768 968 429

www.con-formgroup.com.au



1300 882 490



info@con-formgroup.com.au